



# Small-Scale Multi-Unit Housing Application Guide

*April 2026*



**April 2026:** This version includes new information on [Page 15](#) regarding including an existing building in a proposed strata plan.

# DISCLAIMER

## **This is not a legal document.**

It does not outline all applicable regulations. Rather, it provides a summary of many of the regulations and processes that applicants should consider when exploring SSMUH development.

Any contradiction, dispute, or difference between the contents of this document and applicable provincial law or City bylaws, plans, policies, or guidelines will be resolved by reference to the law, bylaws, or other official documents.

# CONTENTS

---

<b>INTRODUCTION</b>	<b>6</b>
What is Small-Scale Multi-Unit Housing (SSMUH)?	6
What are the SSMUH housing types in Abbotsford?	6
<b>GETTING READY TO APPLY</b>	<b>7</b>
Pre-Application Meeting	7
Zoning Regulations	7
Engineering Requirements	7
Other considerations that may impact the number of units?	9
Required Permits	10
What information do I need to include in my application?	10
Permitting Process	11
<b>DEVELOPMENT COSTS</b>	<b>12</b>
Building Permit Fee	12
Development Cost Charges (DCCs)	12
Amenity Cost Charges (ACCs)	12
Development Engineering Fees	13
<b>GUIDE TO ZONING REGULATIONS</b>	<b>14</b>
SSMUH Typologies	14
How many units are allowed on my property?	15
Principal Units	15

Accessory Units	15
Tenure	15
Subdivision	16
Can I create a lot smaller than 495 m <sup>2</sup> ?	16
How big can my building(s) be?	17
Lot Coverage	17
Building Height	18
Building Separation	19
Form and Character	20
Paved Area for Driveways	21
Landscaped Area	22
<b>BYLAW TRANSITION</b>	<b>23</b>
What if I want the new zoning?	23
<b>OTHER ZONING BYLAW UPDATES</b>	<b>24</b>
What has changed?	24
What if I have an active building permit application?	25
What if I want to make changes to my issued permit?	25
<b>SSMUH DEFINITIONS</b>	<b>26</b>

# INTRODUCTION

## What is Small-Scale Multi-Unit Housing (SSMUH)?

In November 2023 the Province of BC introduced legislation requiring cities across the province to permit up to 6 housing units on most properties that were previously limited to single detached dwellings or duplexes.

This type of housing, known as Small-Scale Multi-Unit Housing (SSMUH) can take on a range of configurations that can provide more affordable housing for middle-income families.

## What are the SSMUH housing types in Abbotsford?

In Abbotsford, examples of SSMUH include combinations of the following up to 4 units on one lot:

- » Single Detached Dwellings
- » Duplexes
- » Townhouses
- » Secondary Suites
- » Garden Suites
- » Coach Houses

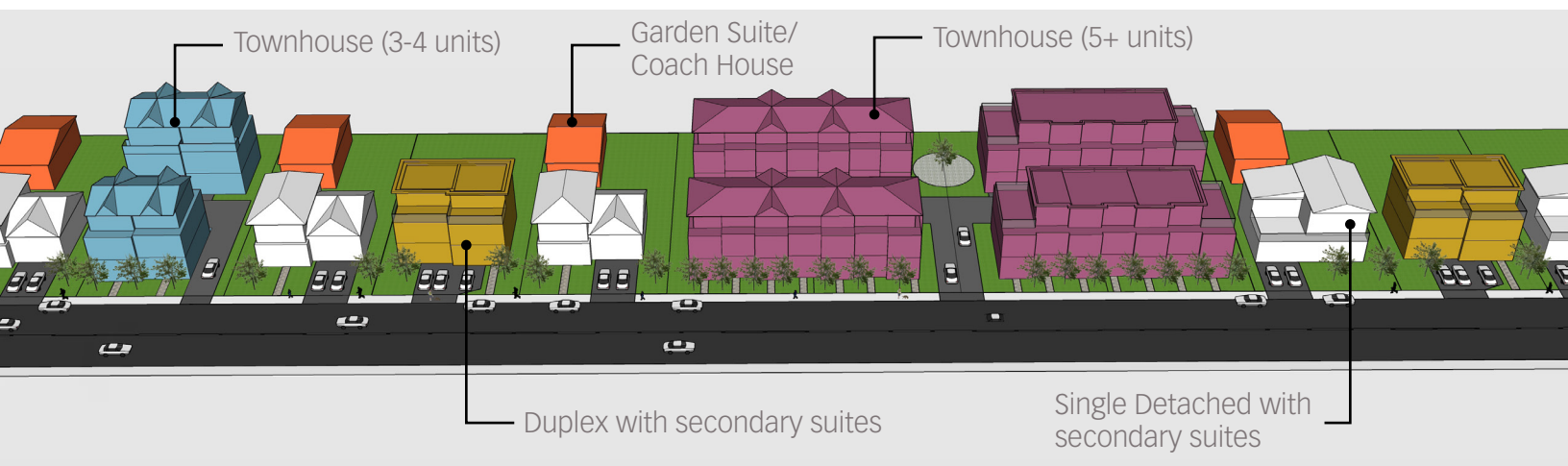

# GETTING READY TO APPLY

## Development Inquiry Meeting

Prior to investing time and money into project planning and design, it is strongly recommended that you book a Development Inquiry Meeting (DIM) to get a complete understanding of what is involved. This is where you will learn if any road dedication is required, what service and road upgrades may be needed, what fees and charges are applicable to the project, and how the Official Community Plan, Zoning Bylaw, and any other bylaws or policies will guide development on the property.

Visit the [website to book a DIM](#) or contact the [Building Department](#) at 604-864-5525.

## Zoning Regulations

You can use the City's online WebMap to see what any property is permitted, following these instructions:

1. [Launch WebMap](#)
2. Navigate to the property you are interested in
3. Click on the property and identify the zoning
4. [Open the Zoning Bylaw](#)
5. Review the regulations applicable to the property

## Engineering Requirements

Before submitting an application, make sure you have fully considered the costs and impacts associated with satisfying the City's engineering requirements associated with new, or the replacement of existing services (e.g. sanitary, storm, and water).

### Road Dedication

In many situations, road dedication is required to bring the fronting road right-of-way up to municipal standards to accommodate future growth. If the existing road right-of-way width is less than the required standard, dedication will be required. Map M-1210 in the [Development Bylaw](#) identifies the required widths for arterial and collector roads within the Urban Development Boundary. Parcels fronting local roads may also require road dedication if the fronting right-of-way is below municipal standard.

### Road Dedication - *continued*

In addition, corner lots may also be required to provide a corner truncation dedication, the size of this is determined by the table below:

Intersecting Road	Truncation
Arterial and Collector to any Roadway or Lane	5.0 m x 5.0 m
Local Road to Local Road	3.0 m x 3.0 m
Local Road to Lane	1.5 m x 1.5 m
Lane to Lane*	5.5 m x 5.5 m

\* Lane to lane corner cuts are required for garbage truck and fire truck access.

As road dedication can impact the development potential of a lot, the City's Development Engineering staff should be consulted early on to discuss potential road dedication requirements. If road dedication is required, the proposed site plan should be adjusted to accommodate the new setback.

### Frontage Improvements & Site Servicing

SSMUH developments require updated site servicing, as described in the [Development Bylaw](#), which may include construction or cash contributions for frontage improvements - such as roads, curbs, sidewalks, boulevards, and streetlights - or upgrades to water, sewer, and drainage systems to support the added density. Applicants are strongly encouraged to retain a civil engineering consultant to determine servicing requirements early on, as the associated costs may affect the feasibility of the development.

### Access

Access requirements for a parcel can affect the design and layout of SSMUH developments. The classification of the fronting road, presence of lanes, and type of housing form selected will affect the location and width of driveways. Each parcel will be limited to a single driveway, unless otherwise approved by the City. Where a corner lot adjoins roads of different classifications, access is typically limited to the lower classification road, unless otherwise approved by the City.

### Drainage

The [Development Bylaw](#) requires applicants to explore infiltration to manage storm water on site where possible. Applicants should hire a Qualified Professional (QP), such as a geotechnical engineer, to review the suitability of on-site soils for infiltration. Existing storm water service connections cannot be re-used unless a QP proves that the property is not suitable for infiltration.

A consulting civil engineer should be engaged with early on to determine the potential design solutions for stormwater management and how it may affect the location of the building.

### **Third Party Utility Upgrades**

We recommend reaching out to appropriate utility companies with your development plans to verify any utility upgrades and associated costs. The building permit process does not include the evaluation of third-party utility capacities and it is the applicant's responsibility to ensure that the development will be properly serviced.

## **Are there any other considerations that may impact the number of units?**

### **Registered Legal Documents**

Applicants are required to provide a [State of Title Certificate](#) as part of a building permit application. Some properties may have restrictions that impact development options. Neither the provincial housing legislation nor the City's Zoning Bylaw over-ride covenants, therefore the uses on the property must be compliant with any restrictions.

### **Agricultural Land Reserve**

In some cases, a property may be eligible for SSMUH but located within the Agricultural Land Reserve (ALR). In these cases, the Agricultural Land Commission Act and the ALR Use Regulation prevail, limiting development to the following:

- » a principal residence up to 500 m<sup>2</sup> total floor area;
- » a secondary suite within that principal residence; and
- » an additional residence up to 90 m<sup>2</sup> total floor area for parcels 40 ha or less, or up to 186 m<sup>2</sup> for parcels larger than 40 ha.

### **Ministry of Transportation**

The Ministry of Transportation requires a 4.5 m setback from property lines adjacent to a provincial highway (i.e. Highway 1 and 11). In some cases this may be greater than the setback required by the City's Zoning Bylaw and should be taken into account during project planning.

## Required Permits

### Development Permit

The City does not require a Form and Character Development Permit for residential development with 4 or fewer units. However, for properties located on or near steep slopes or environmentally sensitive areas, adjacent to the Agricultural Land Reserve, or within the McKee Neighbourhood Plan, a Development Permit may be required.

### Tree Cutting Permit

Applicants are encouraged to retain trees wherever possible. In accordance with the [Tree Protection Bylaw](#), prior to removing, topping, excessively pruning, or otherwise damaging a substantial tree, a [Tree Cutting Permit](#) is required.

### Building Permit

A [Building Permit](#) is required to construct new housing or to complete a renovation to add additional housing units. This work is subject to the [BC Building Code](#) and all applicable bylaws, regulations, and enactments, including the City's [Building Bylaw](#). Different versions of SSMUH will be subject to different Building Code requirements. For instance, a Duplex with Secondary Suites falls under Part 9 of the code, while a Townhouse may need to be designed under Part 3. These differences can affect the cost of construction.

For more information on the Building Code, and how your project may be affected you should consult a building designer, architect, and/or engineer with expertise in the BC Building Code.

Remember, [Building Permits can now be submitted online!](#)

## What information do I need to include in my application?

Everything you need to know about what to include in your application is available on the City's website. The website includes checklists detailing what must be included, which, alongside this guide, will help you prepare your application.

## Permitting Process

SSMUH applications should be submitted with a conceptual servicing plan and rainwater management plan to ensure that the required servicing standards have been integrated with the building design. During the building permit process, a detailed engineering review occurs to ensure that designs meet municipal standards.

Before your building permit is issued, you will be required to enter into a servicing agreement and provide the payments, securities, and fees for the design and construction of these municipal services and frontage improvements. Following building permit issuance, your civil consultant will request a pre-construction meeting where your contractor will meet with pertinent City inspection and operations staff prior to starting construction.

# DEVELOPMENT COSTS

There are many potential costs that may be applicable to your development. To avoid surprises, we strongly recommend fully understanding these costs prior to undertaking substantial design work.

## Building Permit Fee

In accordance with Schedule "G" of the Fees and Charges Bylaw, a non-refundable application fee of \$750 is required as part of a SSMUH building permit application. The application fee is then credited to the building permit fee, which is calculated after plan review based on the construction value of the project.

## Development Cost Charges (DCCs)

DCCs are fees set by the City to offset some of the financial costs of new development and are collected with a building permit or subdivision. They are used to pay for large growth-related off-site infrastructure such as water supply and treatment, sewage collection and treatment, drainage facilities, major road upgrades, fire, police, solid waste facilities, and new park acquisitions. DCCs are applicable to most developments, with the exception of places of worship, building permits with a construction value of less than \$50,000, and residential units smaller than 29 m<sup>2</sup>.

The DCC rate for SSMUH (as of February 1, 2026) is \$27,903 per unit and a credit may be applied for any existing units on the property. For example, if a 4-unit townhouse replaces a single detached dwelling, the DCC rate is  $(\$27,903 \times 4 \text{ units}) - \text{single detached dwelling rate } (\$57,032) = \$54,580$ .

## Amenity Cost Charges (ACCs)

ACCs are cost charges levied on development to offset the demand for new social, cultural, heritage, recreational, or environmental facilities or features in the community. They help the City fund things such as community centres, recreational facilities, libraries, daycares, and public squares, etc.

The ACC rate for SSMUH (as of February 1, 2026) is \$3,840 per unit. Contributions previously made via the City's Community Amenity Contributions (CAC) policy may be credited against any applicable ACC charge.

Developments that do not result in an increase in population, and some types of affordable housing ([as prescribed by the Province](#)), are exempt from paying ACCs.

## Development Engineering Fees

As part of the servicing agreement process, your consulting civil engineer will provide a cost estimate for the required works and services. An administration and inspection fee of 5% of the estimated cost of the works and services will be charged prior to entering into the servicing agreement. A security deposit will also be required at 110% of the estimated cost of the works and services. For more information on the servicing agreement process, applicants should contact [Development Engineering](#) at 604-864-5510 or [planning-info@abbotsford.ca](mailto:planning-info@abbotsford.ca).

# GUIDE TO ZONING REGULATIONS

## SSMUH Typologies

SSMUH can take on a variety of different forms, from single detached dwellings to townhouses. The City’s approach is to enable the required number of units per lot, in accordance with provincial legislation, with flexibility increasing as you move closer to the urban core.

Below are examples of the types of housing permitted across different SSMUH zones.

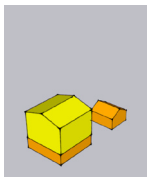
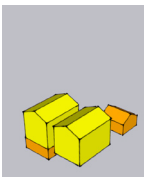
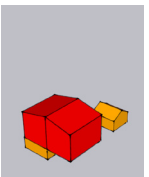
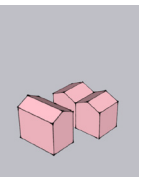
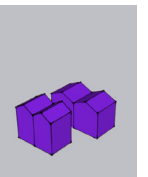
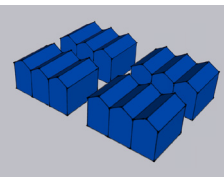
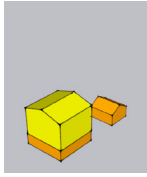
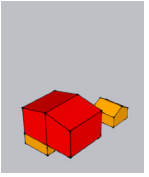
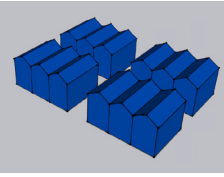
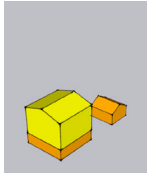
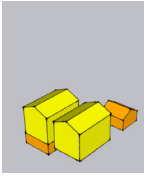
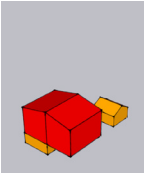
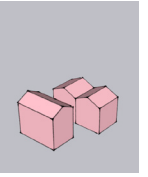
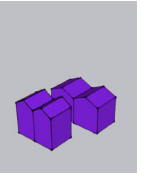
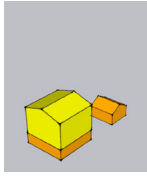
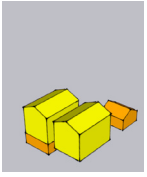
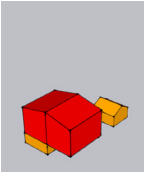
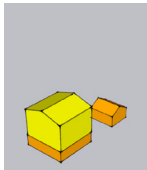
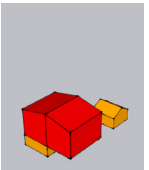
	Detached + Accessory Unit(s)	Detached (2) + Accessory Unit(s)	Duplex + Accessory Unit(s)	3 unit Townhouse	4 unit Townhouse	5+ unit Townhouse
TH1						
TH2						
SSMUH 1						
SSMUH 2						
SSMUH 3/4						

## How many units are allowed on my property?

The maximum number of units that are permitted on a property depends on the size of the property and where it is located, as follows:

- » 3 units on lots 280 m<sup>2</sup> or smaller
- » 4 units on lots bigger than 280 m<sup>2</sup>
- » no unit max on TH zoned properties that are larger than 1,120 m<sup>2</sup> and wider than 35 m

## Principal Units

Principal units are those listed under *Principal Uses* in the applicable zone. In SSMUH 2, 3, and 4 areas a maximum of 2 principal units are permitted, in the form of single detached dwellings and duplexes. These can be supplemented with accessory units, like secondary suites and garden suites/coach houses, up to the maximum permitted number of dwelling units established in the zone. In SSMUH 1, up to four principal dwellings units are permitted, in the form of a townhouse.

## Accessory Units

SSMUH development may include accessory units like secondary suites, garden suites, and coach houses. All accessory units count towards the total number of units permitted on a property.

A secondary suite is fully contained within a principal dwelling unit and must be less than 50% of the size of the principal unit within which it is located.

Garden suites and coach houses are allowed to occupy up to 15% of the lot area, to a maximum of 100 m<sup>2</sup>.

## Tenure

Principal units (single detached, duplex, and townhouse units) can be either rental or owned. Secondary suites, garden suites, and coach houses are considered accessory units and cannot be sold independently from the principal unit to which they are accessory.

It's important to determine if you want to stratify and sell units, or offer them as rental. It may be simpler to stratify units at the time of construction than after an occupancy permit has been issued.

If an existing building is to be included in a strata plan, an application to the City is required in accordance with section 242 of the [Strata Property Act](#). The application must include a report on the items listed in section 8 (L) on page 6 of the City's [Development Application Form](#).

## Subdivision

Most SSMUH zones (incl. TH zones) permit a minimum subdivision size of 495 m<sup>2</sup> (SSMUH 3 and 4 are for larger properties). Minimum lot width differs across zones based on the housing types permitted. For example, SSMUH 1 and TH1 zones allow lot widths of 16.5 m, which accommodates a 4-unit townhouse with internal parking/access. SSMUH 2 and TH2 allow lot widths of 20 m, to accommodate duplexes with suites and parking out front.

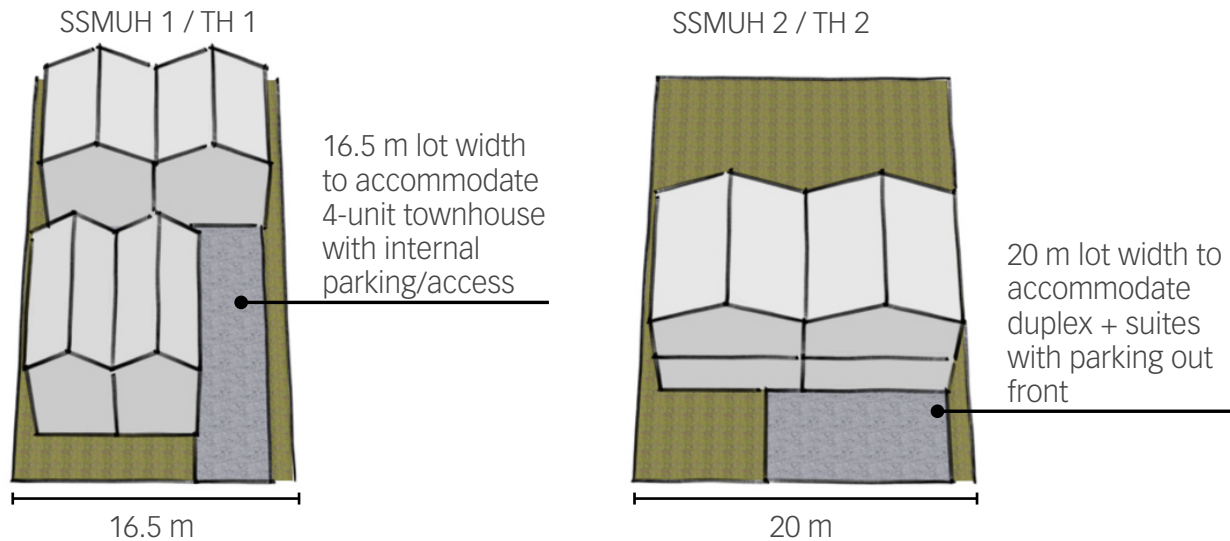

In both cases, the intent is to enable lots that accommodate the necessary housing and parking while retaining enough of the lot frontage for other things, like yards, trees, and drainage.

## Can I create a lot smaller than 495 m<sup>2</sup>?

Yes, the Official Community Plan contemplates lots smaller than 495 m<sup>2</sup> in the SSMUH 1 and SSMUH 2 land use designations, and some Townhouse designated areas. To enable smaller lots, a rezoning application is required. For example, if your property is designated SSMUH 1 in the OCP, you can apply to rezone your property to the RS7 zone, which allows 300 m<sup>2</sup> lots.

**Note:** Traditional single detached zones like RS7 are permitted up to 4 units per lot, subject to the development regulations contained within the zone. For example, in RS7 development is permitted a maximum density of 0.5 FSR, compared to SSMUH 1, where permitted density is up to 1.2 FSR depending on housing type.

## How big can my building(s) be?

Building size is regulated by Floor Space Ratio (FSR), which is a ratio of building size relative to lot size. For example, an FSR of 0.5 means that the maximum size of the building is equal to 50% of the size of the property.

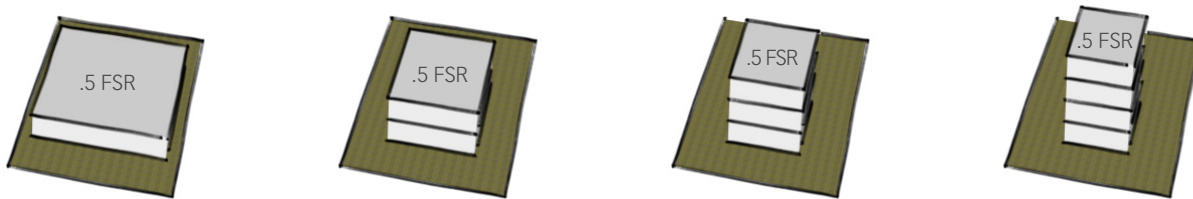

One of the key principles of the City's SSMUH approach is to provide additional density to accommodate more housing units, not bigger houses. As a result, permitted FSR for SSMUH depends on the type of development proposed and increases as units are added to a property, as follows:

Housing Type	FSR (max)
Single Detached with/without secondary suite	0.5
Single Detached with/without secondary suite and garden suite/coach house	0.65
Duplex with/without secondary suite(s) and/or garden suite/coach house	0.65
Townhouse with 3 units	0.9
Townhouse with 4 units	1.2
Townhouse with 5+ units	1.5

**Note:** Not all SSMUH typologies listed above are permitted in all zones. To determine what is allowed on your property, see the **SSMUH Typologies** section on page 14 or the [Zoning Bylaw](#). Remember, if you are using a traditional zone, like RS7, development is subject to the development regulations in the zone (e.g. 0.5 FSR regardless of housing type).

## Lot Coverage

Lot coverage regulations dictate the percentage of a lot that can be covered with buildings and/or structures. In SSMUH zones, lot coverage differs based on the housing type proposed (e.g. in SSMUH 1 single detached = 50% and townhouse = 75%).

Importantly, lot coverage is calculated on net lot area, meaning the size of the lot after things like road dedication.

## Building Height

Within SSMUH zones, different housing types have different building height permissions, as follows:

Housing Type	Building Height (max)
Garden Suite	4.5 m or 1 Storey
Coach House	7.5 m or 2 Storeys
Single Detached	9.5 m or 3 Storeys
Duplex	9.5 m or 3 Storeys
Townhouse*	11.0 m or 3 Storeys

- \* Townhouse buildings are permitted 9.5 m in height where located within 15 m of a rear property line (a) or where separated from the street by another building (b). This is to mitigate impacts on neighbouring properties.

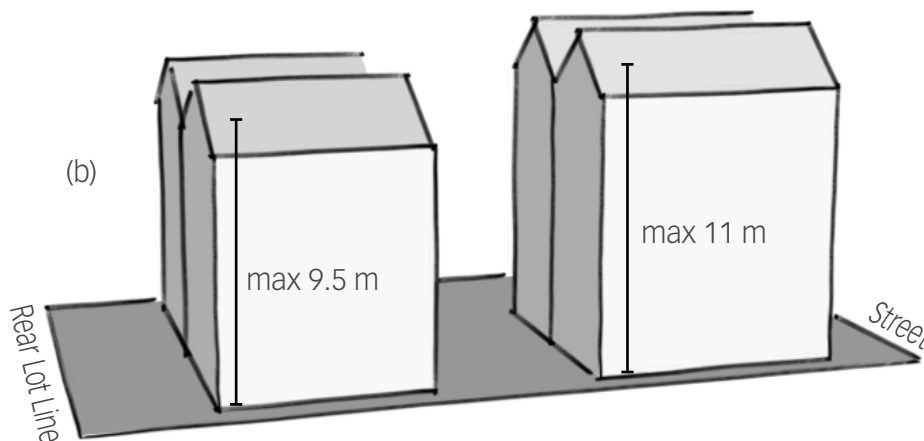
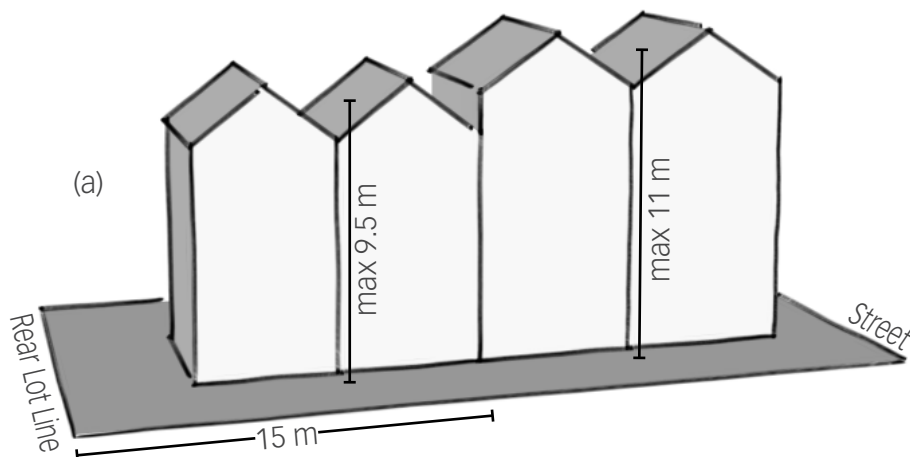

## Building Separation

To support liveability, privacy, and safety in the event of a fire, buildings need to be placed a certain distance from one another. The Zoning Bylaw requires a minimum of 2.4 m between buildings that are side-by-side and a minimum of 6 m between buildings placed front-to-back on the property.

It is important to note that the BC Building Code may require greater distances between buildings depending on the design of each building.

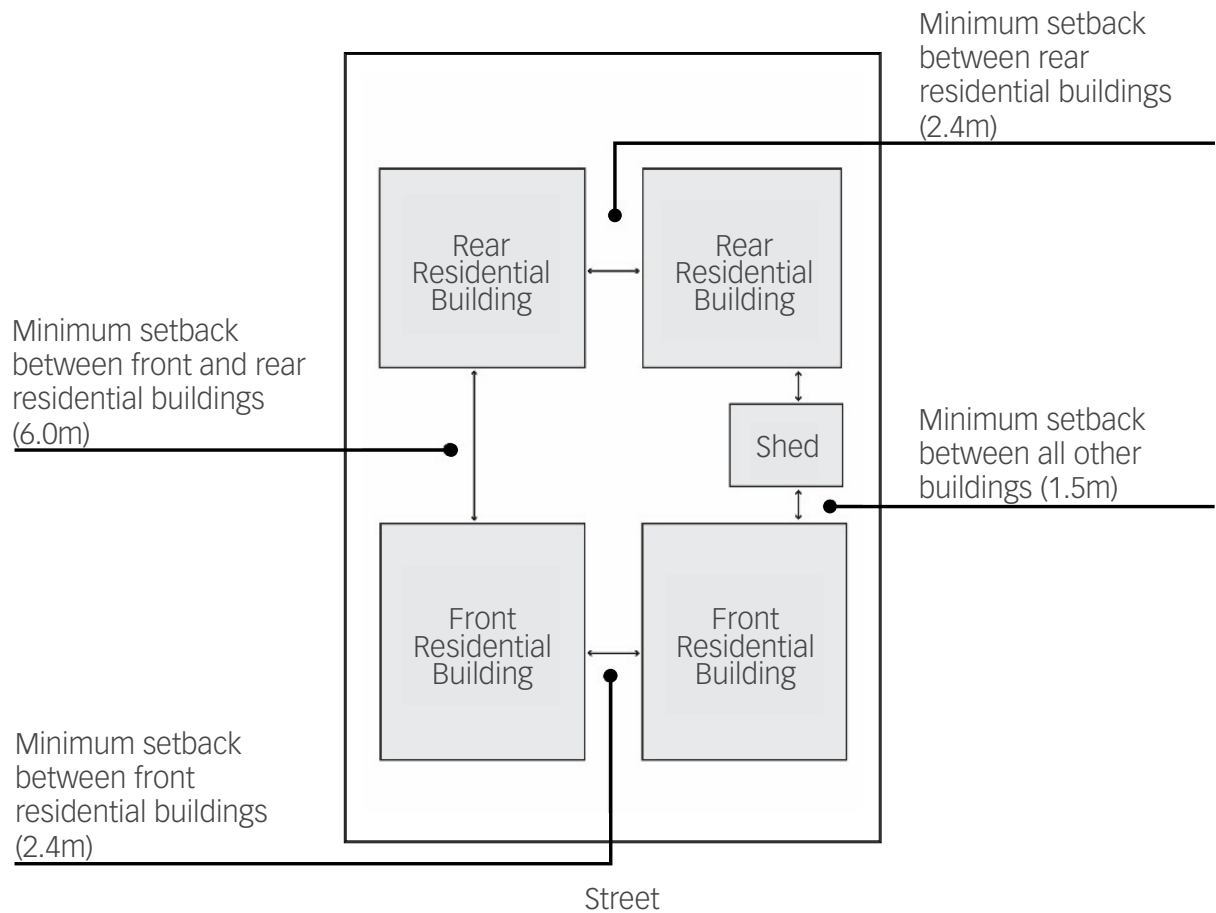

## Form and Character

While the City does not require Form and Character Development Permits for residential development with 4 or fewer units, SSMUH zones include regulations to ensure that new development sensitively integrates into its surroundings. In particular, townhouse development must include the following:

- » a front door with an adjacent window, facing the street;
- » a pathway that connects the front door to the sidewalk;
- » a covered, unenclosed porch that is at least 3 m wide and 1.5 m deep;
- » at least 15% of the street facing side of the building must be glazed (i.e. windows); and
- » building articulation of at least 0.6 m for at least 50% of the street-facing side of the building.

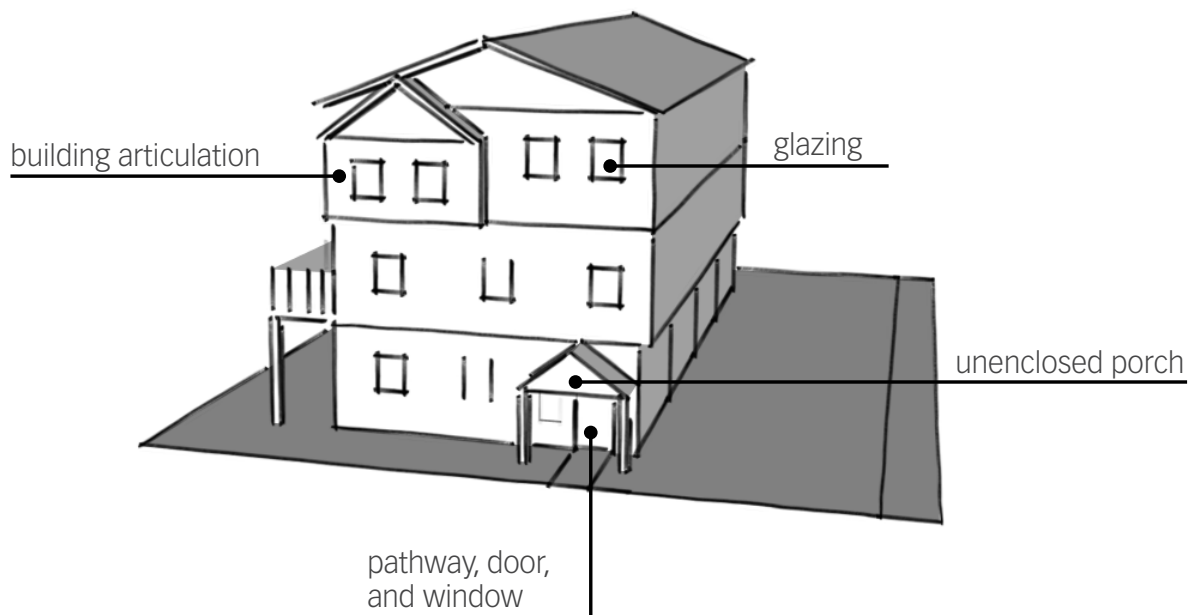

## Impermeable Surfaces

SSMUH zones include a maximum lot coverage for impermeable surfaces. This includes all areas of a property that are covered by buildings, paved areas, and other materials that substantially impede water infiltration. This is to ensure that enough space on a lot is left over for yards, trees, and drainage.

## Parking

Parking requirements are found in [Section 150 of the Zoning Bylaw](#) and depend on the housing type(s) proposed, as follows:

Housing Type	Required Stalls / Unit (min)
Single Detached Dwelling	2
Duplex	
Townhouse (5+ unit)	2 + 0.2 visitor
Townhouse (3-4 unit)	1.5
Secondary Suite	1
Garden Suite	
Coach House	

## Paved Area for Driveways

To accommodate the necessary housing while retaining safe, attractive, and well-functioning streets, the Zoning Bylaw features maximum paved area for driveways, based on the width of the lot and the number of units.

### Lots less than 20 metres wide (SSMUH 1 & TH 1 Zones only)

On a lot that is less than 20 metres wide and has fewer than 3 units, the maximum paved area between the property line and the garage(s) is 6 metres in width. If there are 3 or 4 units, the maximum width increases to 9 metres.

This means that in SSMUH 1 and TH1, where a lot is narrower than 20 metres, and where 4 units are proposed, parking must be provided internal to the site because 9 metres is not sufficient to accommodate 4 parking stalls (min 2.7 metres width per stall).

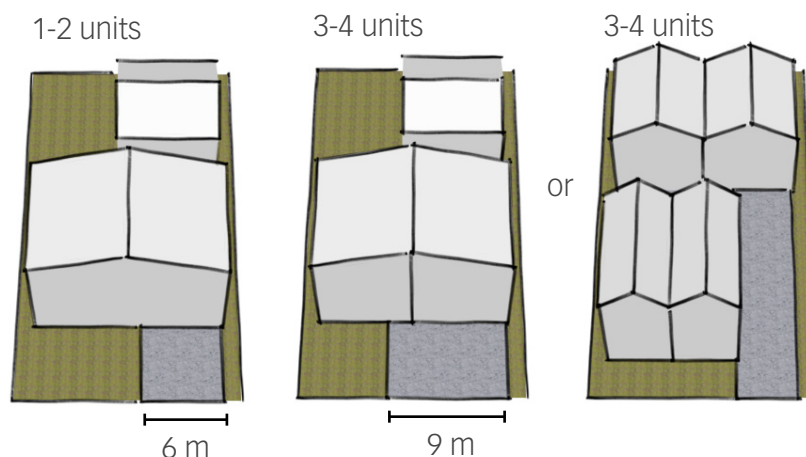

### Lots 20 metres or wider

On a lot that is at least 20 metres wide and has fewer than 3 units, the maximum paved area width between the sidewalk and the garage(s) is 6 metres. If there are 3 or 4 units, maximum width increases to 11 metres.

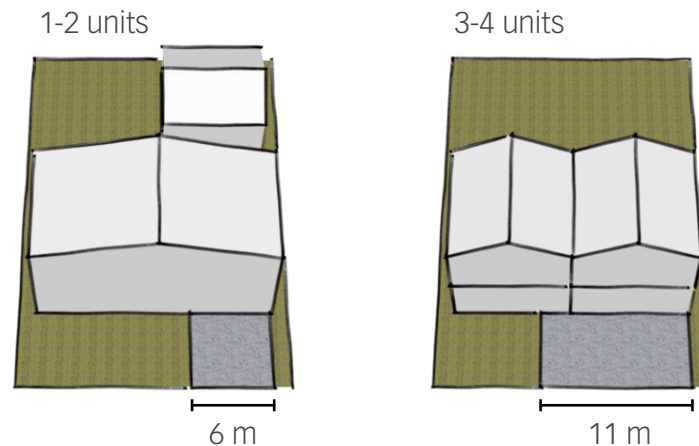

### Landscaped Area

In SSMUH and TH zones, the front setback area must have continuous landscaped area of at least 3 metres (excluding accessways), as well as a 1.2 metre landscaped area between off-street parking areas/driveways and directly abutting lots. If a driveway is shared between properties then there is no landscape requirement.

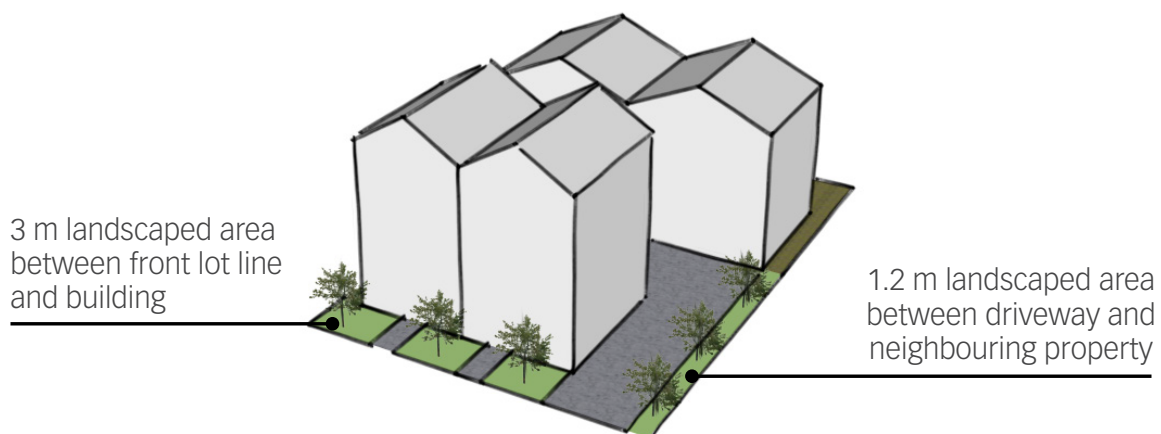

# BYLAW TRANSITION

To facilitate a smooth transition to updated zoning regulations, the City has adopted a transition approach that recognizes active applications, allowing them to continue the development process without being impacted by new regulations. In essence, where an active development application is ultimately completed, the property can retain the zoning in place at the time of completion.

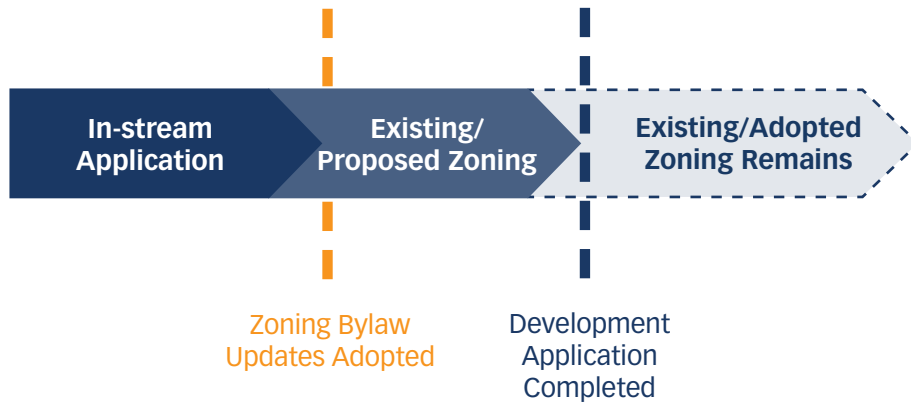

## What if I want the new zoning?

If you currently have an application under review but would prefer to receive the new zoning, you can either withdraw your application or submit a request by letter to Planning and Development Services.

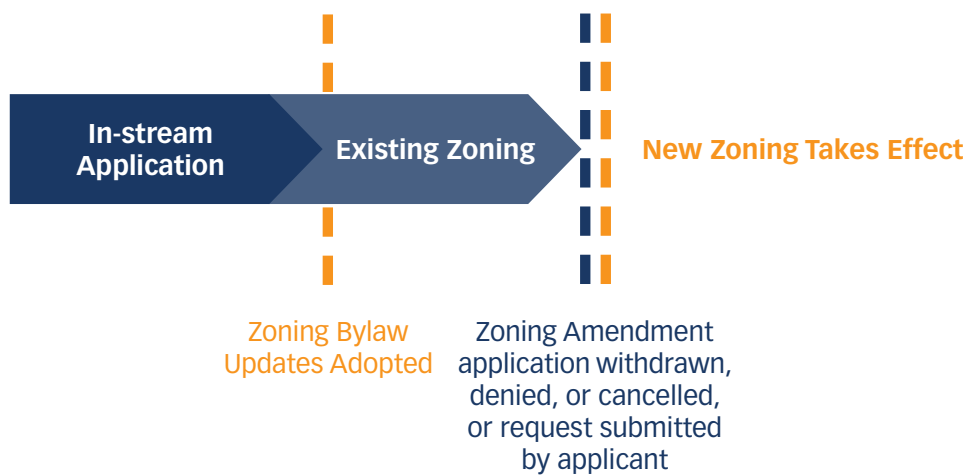

# OTHER ZONING BYLAW UPDATES

In addition to specific zoning bylaw updates for SSMUH, other updates were introduced to guide residential development more broadly. In general, the updates increase permissions for residential uses and, as a result, some applicants may wish to amend their applications to take advantage of the new rules.

## What has changed?

Some of the more notable changes include:

### **Building Floor Area**

Changes to Zoning Bylaw definitions of *Floor Area, Net* and *Floor Area, Gross* impact the way that floor area is calculated.

*Floor Area, Net* is used to calculate the permitted size of multi-unit residential buildings, like townhouse and apartment buildings. The changes mean that common areas like hallways, elevators, stairwells, and maintenance/mechanical rooms no longer count towards the calculation of Floor Space Ratio (FSR). In addition, the amount of common indoor amenity area that is exempt has increased from 100 m<sup>2</sup> to 300 m<sup>2</sup>.

*Floor Area, Gross* is used to calculate the permitted size of Single Detached Dwellings and Duplexes. The changes mean that up to 30 m<sup>2</sup> of attached garage no longer counts when calculating the maximum permitted size of a building.

These changes result in the ability to build larger buildings than was possible prior to the updates.

### **Building Height**

Some new and updated zones increase the permitted building height for single detached and duplex dwellings to 9.5 metres, where it was previously a maximum of 8.5 m. This means that all single detached houses and duplexes across the city are now allowed to be 9.5 m in height.

### **Apartment Density (RMM Zone)**

Permitted floor area in the RMM Zone has been updated to permit a maximum of 2.5 FSR, regardless of the size of the lot. This means that a building on an RMM zoned property that is larger than 2,500 m<sup>2</sup> is now permitted more building floor area than before.

### **Upper Storey Setbacks**

Zoning updates remove the requirement that the upper storey of single detached and duplex dwellings in the infill area be limited to a maximum of 80% of the storey directly below.

### **Secondary Suite Size**

Changes to secondary suite regulations update the maximum size (in most zones) from 100 m<sup>2</sup> to less than 50% of the size of the principal unit to which it is accessory.

For example, if a single detached dwelling is a total of 240 m<sup>2</sup> then the secondary suite can occupy a maximum of 119 m<sup>2</sup>. This creates more flexibility for secondary suites and may lead to larger suites than were previously allowed.

## **What if I have an active building permit application?**

If you have a building permit application under review but would like to make changes based on the updated regulations you can amend your application. Please review these updates and discuss with the designer, architect, or engineer responsible for preparing your plans.

## **What if I want to make changes to my issued permit?**

If you have been issued a building permit but would like to make changes to take advantage of the updated zoning regulations, you do not need to submit a new application. Please review the updates and discuss with the designer, architect, or engineer responsible for preparing your plans.

# SSMUH DEFINITIONS

This section is provided for convenience only and includes many of the commonly used Zoning Bylaw definitions associated with SSMUH development. For a complete list of definitions, see [section 120 of the Zoning Bylaw](#).

**Coach House** means a Dwelling Unit that is Accessory to a Single Detached Dwelling or Duplex on the same Lot, located on the second Storey of an Accessory Building, and is part of the same real estate entity.

**Duplex** means a residential Building consisting of two principal Dwelling Units attached horizontally or vertically, where each Dwelling Unit has an independent entrance either directly from the outside or through a common vestibule. Where permitted by this Bylaw, each principal Dwelling Unit in a Duplex may contain one Secondary Suite.

**Dwelling Unit** means one or more habitable rooms in which sleeping, sanitary and cooking facilities are located in a self-contained areas.

**Floor Area, Gross** means the total area of all Storeys in all Buildings on a Lot measured to the inside face of the exterior walls of the Building. For Single Detached Dwellings and Duplexes, this shall exclude an Accessory Building, with a maximum size of 10 m<sup>2</sup>, and enclosed off-street parking spaces located within an attached garage, to a maximum of 30 m<sup>2</sup>.

**Floor Area, Net** means Gross Floor Area, less any of the following:

- (6) Underground Parking and concealed parking areas, unless such parking is a principal use, long term bicycle parking and at-grade areas used for off street loading;
- (7) common corridors, hallways, landings, foyers, elevators, staircases and stairwells;
- (8) common areas used for maintenance, mechanical, or electrical purposes;
- (9) building areas with a ceiling less than 1.2 m in height; and/or
- (10) for multi-unit residential Uses only: common indoor amenity areas up to 3 m<sup>2</sup> per unit or 300 m<sup>2</sup>, whichever is less.

**Floor Space Ratio (FSR)** means:

- (1) for Single Detached Dwellings and Duplexes, the figure obtained by dividing the Gross Floor Area by the Lot Area as illustrated in Figure 2; or
- (2) for all other uses, the figure obtained by dividing the Net Floor Area of all Buildings and Structures on a Lot by the Gross Lot Area.

**Figure 2 – FSR for Single Detached Dwellings and Duplexes**

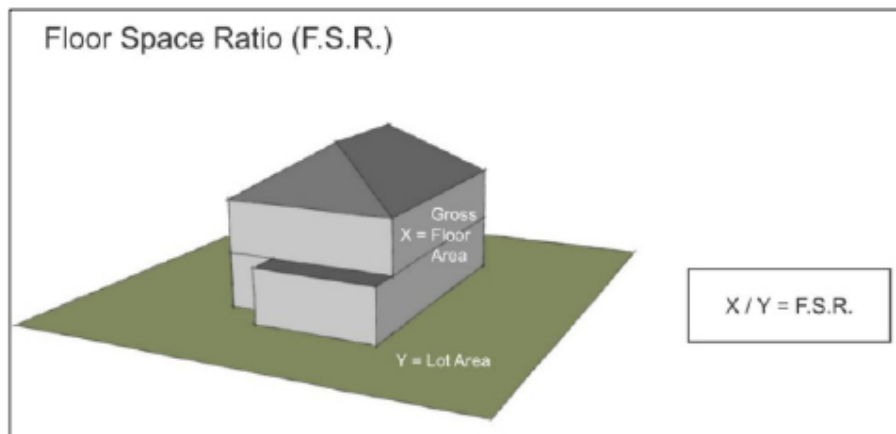

**Garden Suite** means a Dwelling Unit that is Accessory to a Single Detached Dwelling or Duplex on the same Lot, located in a single Storey Accessory Building, and is part of the same real estate entity.

**Impermeable Surface** means any constructed or compacted surface that prevents or substantially impedes the infiltration of water into the ground naturally. This includes, but is not limited to buildings and structures, paved or concrete surfaces, asphalt, patios, and artificial turf.

**Landscaped Area** means a decorative planting area containing trees and any combination of shrubs, plants, flowers, bark mulch, decorative boulders, decorative paving, planters, sculptures, and the like, planted and maintained to enhance and embellish the appearance of a property.

**Principal Building** means any Building to accommodate a Principal Use.

**Secondary Suite** means a Dwelling Unit that is Accessory to, and within, a principal Dwelling Unit, and is part of the same real estate entity.

**Single Detached Dwelling** means a residential Building consisting of one principal Dwelling Unit on one Lot, and where permitted by this Bylaw, one Secondary Suite.

**Small-Scale Multi-Unit Housing** means a residential Building, or Buildings, containing a maximum of four Dwelling Units on one Lot, and may be any combination of the following:

- (a) Single Detached Dwelling
- (b) Duplex
- (c) Garden Suite
- (d) Coach House; and/or
- (e) Secondary Suite

**Townhouse** means residential Buildings, or portions of Buildings, consisting of three or more principal Dwelling Units on a Lot, where each Dwelling Unit has direct ground level access, or indirect ground level access by way of a staircase shared by not more than two Dwelling Units on the same Storey.



## Building Permits & Licenses

604-864-5525

[building-info@abbotsford.ca](mailto:building-info@abbotsford.ca)

## Planning Services

604-864-5510

[planning-info@abbotsford.ca](mailto:planning-info@abbotsford.ca)

Abbotsford City Hall  
32315 South Fraser Way, Abbotsford, BC V2T 1W7



[city-of-abbotsford](https://www.linkedin.com/company/city-of-abbotsford)



[thecityofabbotsford](https://www.instagram.com/thecityofabbotsford)



[City\\_Abbotsford](https://twitter.com/City_Abbotsford)